

# STELRAD ELECTRIC CLOUD INSTALLATION INSTRUCTIONS

## Health and Safety

Consult your employers manual handling risk assessment before manually handling any radiators. Many of Stelrad's products are more than 25Kg. Care should be taken, and assistance sought when lifting large, heavy and bulky loads to avoid potential injuries. Safety gloves are advisable for protection.

For your own safety please refrain from placing your hands – fingers between and down the back of the radiator to prevent possible injury.

## Symbols used in the manual



IMPORTANT!

Danger for the safety of persons, pets and things.



IMPORTANT!

High temperatures. Risk of burns.



IMPORTANT!

Danger electric shock.



Tips for efficient operation.



IMPORTANT!

Danger of damage to the appliance.



DO NOT COVER THE APPLIANCE!

## WARNING



### CAUTION:

Some parts of this product can become very hot and cause burns. Particular attention must be given where children and vulnerable people are present.



Children of less than 3 years should be kept away from the towel radiator unless continuously supervised. Children aged from 3 years and less than 8 years shall only switch on/off the appliance provided that it has been placed or installed in its intended normal operating position and they have been given supervision or instruction concerning use of the appliance in a safe way and understand the hazards involved. Children between 3 and 8 years old must not disconnect, regulate and clean the appliance or perform user maintenance. This appliance can be used by children aged from 8 years and above and persons with reduced physical, sensory or mental capabilities or lack of experience and knowledge if they have been given supervision or instruction concerning use of the appliance in a safe way and understand the hazards involved. Children shall not play with the appliance. Cleaning and user maintenance shall not be made by children without supervision.

**Never install the appliance:**

- immediately below or in front of a power socket or a junction box (Fig. 5)
- in contact with the wall or floor.
- near curtains, flammable or combustible materials or pressure vessels.



Install and use the appliance as described in these instructions only.



If the supply cord is damaged, it must be replaced by the manufacturer, its service agent or similarly qualified persons in order to avoid hazard. Never use the appliance if the electronic controls are damaged.



Make sure the fixed power line is fitted with a disconnecting switch allowing the appliance to be disconnected completely from the household mains, included the Pilot Wire, when present, in accordance with the wiring rules.



**WARNING:** to avoid hazardous overheating, never under any circumstances cover the appliance (Fig.7). Never obstruct the air flow by inserting material into the appliance.



Make sure that the power supply line is fitted with a sectioning switch to isolate the appliance, and the control wire if fitted, from the electricity mains according to the regulations in force. The installation must include a multi-pole circuit breaker with a contact opening distance of at least 3 mm.



To dispose of the appliance, comply with current legislation for the disposal and management of waste.

**DISPOSAL**

Make sure the power cable is disconnected from the power line before performing any operation. To remove the appliance, follow the procedure for fixing to the wall in reverse (Scheme 1).



Important information for correct disposal of the product in accordance with EC Directive 2012/19/EC. At the end of its working life, the product must not be disposed of as urban waste. It must be taken to a special local authority differentiated waste collection centre or to a dealer providing this service.

---

**GENERAL INFORMATION**

Unpack the appliance carefully and rest it on the polystyrene corner pieces or a carpet.

The package contains:

- the appliance
- mounting kit
- instructions



Read all the instructions carefully before installation and use. Keep for future consultation.



Install and use the appliance as described in these instructions only.



These instructions do not cover all situations which might arise. Caution and common sense should be applied when installing, operating and servicing the appliance.



Modifying the characteristics of the appliance and removing any fixed component including the caps is expressly prohibited.

Make sure the appliance is complete and undamaged. If damaged, do not use the appliance, but contact your local dealer or a qualified professional.



The materials used for packaging can be recycled. You are therefore recommended to dispose of them in special differentiated waste collection containers.



## WARRANTY

You are recommended to keep all parts of the packaging in case the appliance needs to be returned to the dealer. The appliance must arrive complete and undamaged in order to maintain the validity of the warranty.

The Manufacturer warranties customers all the rights specified in European Directive 1999/44/EC and the consumer rights recognised by national legislation.

The warranty specifically covers all non-conformities and production defects present at the moment of sale or becoming evident within two years from the date of purchase and gives the customer the right to free repair of the defective product or replacement should repair be impossible.

The above rights are invalidated in the following cases:

- defects caused by uses other than those specified in the instructions, which are an integral part of the sales contract;
- defects caused by accidental breakage, negligence or tampering.
- the warranty does not cover any defects due to misuse during handling, transportation or storage processes.

Operations involved in installation, connection to the household mains and maintenance described in these instructions are not covered by the warranty.

The Manufacturer declines all liability for damage or injury caused directly or indirectly to people, objects or pets as a result of the failure to apply these instructions, with particular reference to warnings regarding installation, start-up and use of the product.

To claim the above rights, the Customer must contact his/ her dealer and present a valid proof of purchase issued by the seller, complete with date of purchase.

## POSITIONING AND INSTALLING



The appliance is designed to heat domestic rooms or similar. It must not be used for other purposes. The appliance must be used permanently mounted on a wall as described in the instructions. Install the appliance with the control panel at the top (Fig.2).



### WARNING:

In bathrooms (with bath or shower), install the appliance outside zone 1. The appliance must be installed in such a way that the electronic controls and other control devices may not be touched by someone in the bath or shower. The appliance must not be connected with a plug.



### WARNING:

Respect the distances shown in figures 3,4.



Never install the appliance:

- immediately below or in front of a power socket or a junction box (Fig. 5)
- in contact with the wall or floor
- near curtains, flammable or combustible materials or pressure vessels.



Make sure there are no pipes or electric wires in the wall which could be damaged while mounting the appliance.



The appliance is equipped with a sensor which can detect an open window, if present above the radiator or within the room. For a proper operation, it is strongly recommended to comply to the installation directions reported in before wall mounting.



## WALL MOUNTING



Screws and anchors not included.



Make sure the screws and anchors included in the mounting pack are suitable for the type of wall on which you are mounting the appliance. If in doubt, contact a qualified professional or your local dealer.



During installation, make sure the power cable is disconnected from the power line.



Follow the installation sequence shown on the folding leaf of the cover (Scheme 1), respecting the minimum distance between the bottom of the radiator and the floor (Fig. 3).

## ELECTRICAL CONNECTIONS



### WARNING:

To be installed by a specialised engineer in accordance with the applicable standards in the country concerned. When the appliance is installed, make sure the power is off and the mains switch is in the "O" position.



The appliance requires a 230 V ~ 50 Hz power supply. Make sure the power line is appropriate for the data given in table 1.

Voltage: 230 V - 50 Hz

Insulation class: II 

Protection class: IP24

Power (W)	Length (cm)	Height (cm)	Weight (kg)	Rated current (A)
700	47	58	15,5	3
1000	54	58	17,8	4,3
1500	82	58	23	6,5
2000	103	58	30,5	8,6

Table 1



Make sure the fixed power line is fitted with a disconnecting switch allowing the appliance to be disconnected completely from the household mains, included the Pilot Wire, when present, in accordance with the wiring rules.

If the appliance is installed in a bathroom, the power line must be fitted with a 30 mA RCD (high sensitivity residual current protection device). The power supply line and Pilot Wire control unit must be protected by the same RCD.

Permanently connected appliances must be connected using a connector block placed within a proper junction box.

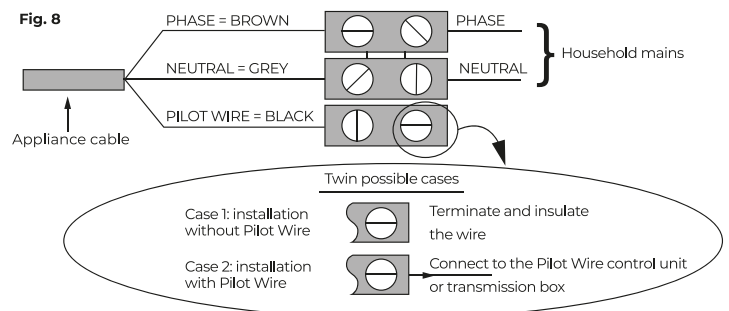
When installing the appliance in damp rooms (kitchen, bathroom), the point of connection with the household mains must be at least 25 cm from the floor. Respect the wiring diagram in figure 8 scrupulously.



If the Pilot Wire is not connected to the programming unit, it must be terminated and insulated. Under no circumstances should the Pilot Wire be connected to the earth.

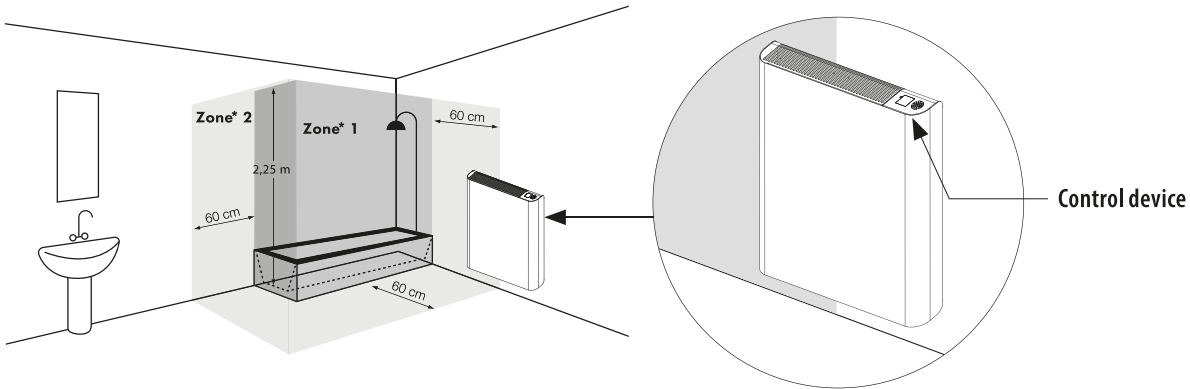


Make sure the power cable cannot in any way come into contact with the surface of the appliance (Fig. 6).



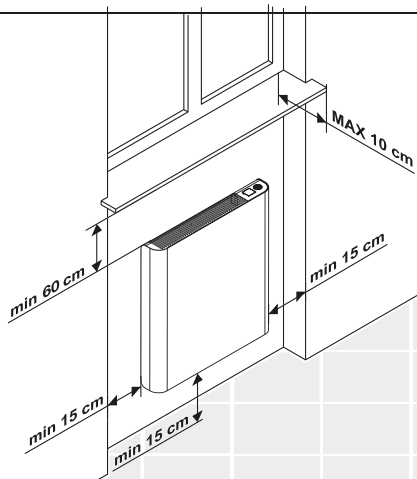


**FIG. 2**

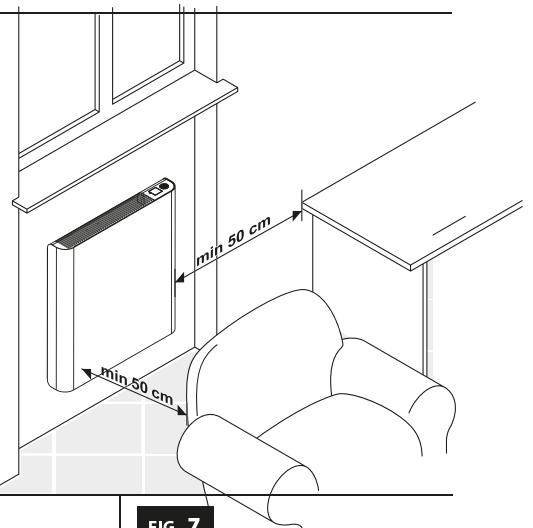


\* Zona / Zone

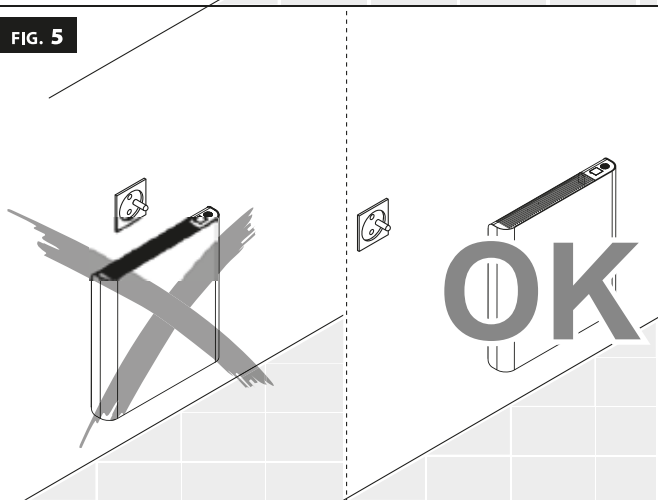
**FIG. 3**



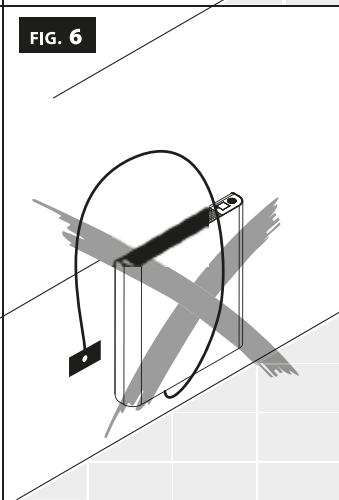
**FIG. 4**



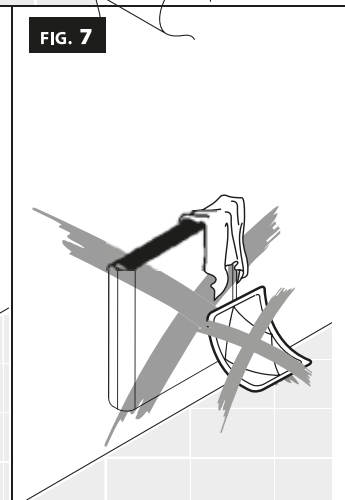
**FIG. 5**



**FIG. 6**



**FIG. 7**





## SCHEME 1

Power (W)	No. of Elements	Y (cm)
700	30	32,3
1000	36	32,3
1500	64	32,3
2000	85	32,3

